

Circleville High School

Honors Algebra 2 Summer Assignment

Part I – Multiple Choice

Even though this part of your summer work is multiple choice, you are required to show supporting work for ALL of your answers.

1. What is the value of the expression

$$1 + \frac{1}{x} + \frac{x}{x^2} + \frac{x^2}{x^3} \text{ for } x = -4 ?$$

- A. $\frac{1}{4}$
- B. $\frac{19}{24}$
- C. $1\frac{1}{12}$
- D. $1\frac{3}{4}$
2. What is the product of $x + 2y + z$ and $2z^2 + 1$?
- A. $x + 2y + 2z^3 + 1$
- B. $2xz^2 + 4yz^2 + 2z^3 + 1$
- C. $2xz^2 + 4yz^2 + 2z^3 + x + 2y + z$
- D. $2xz^2 + 4yz^2 + 2z^2 + x + 2y + z$
3. Joan designed a triangular banner with these dimensions.

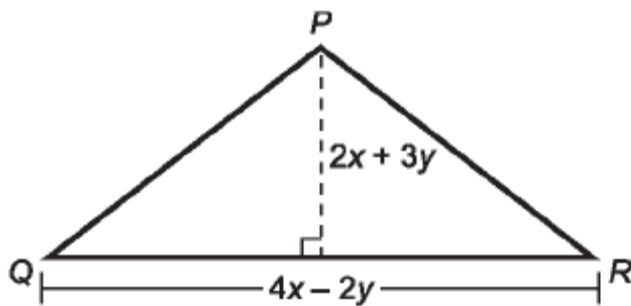

Which expression describes the area of the banner?

- A. $4x^2 + 4xy - 3y^2$
- B. $4x^2 + 8xy - 3y^2$
- C. $4x^2 - 2xy - 6y^2$
- D. $4x^2 + 6xy - 3y^2$

4. A farmer calculates the volume of a water tank by multiplying its length, width, and height. The expressions $x + 1$, $2x + 2$, and $3x + 3$ represent the length, width, and height of the water tank. What is the volume of the water tank?

- A. $6x^3 + 6$
- B. $x^3 + 3x^2 + 3x + 1$
- C. $6x^3 + 6x^2 + 6x + 6$
- D. $6x^3 + 18x^2 + 18x + 6$

5. What value of x makes this equation true?

$$5(x + 4) = 3x + 28$$

- A. 4
 - B. 6
 - C. 12
 - D. 24
6. When a student subtracts 18 from a number, the result is $\frac{1}{4}$ of the number. What is the number?
- A. 6
 - B. 18
 - C. 24
 - D. 36
7. When a student subtracts 7 from a number, the result is greater than $\frac{5}{3}$ of that number. Let x be the number. What are the possible values of x ?
- A. $x > -\frac{21}{8}$
 - B. $x < -\frac{21}{2}$
 - C. $x < \frac{21}{8}$
 - D. $x > -\frac{21}{2}$

8. The formula $s = c + pc$ models the relationship between the selling price, s , the original cost, c , and the profit percentage, p .
- Anna bought a bicycle for \$250 and sold it for \$300. What is her profit percentage?
- A. 60%
 - B. 50%
 - C. 20%
 - D. 17%
9. What is the equation, in standard form, of the line that passes through $(-3, -5)$ and has a slope of 2 ?
- A. $-2x + y = 1$
 - B. $-2x + y = -2$
 - C. $y = 2x + 7$
 - D. $y = 2x + 1$
10. What is the equation, in slope-intercept form, of the line that passes through the point $(-3, 11)$ and has a slope of -4 ?
- A. $y = -4x - 1$
 - B. $y = 12x + 11$
 - C. $y = 4x + 1$
 - D. $y = -4x + 21$
11. What is the equation, in slope-intercept form, of the line passing through the points $(-a, b)$ and $(b, -a)$?
- A. $y = -x - a + b$
 - B. $y = x + 2a$
 - C. $y = -x$
 - D. $y = -x + a - b$

12. Line \overleftrightarrow{QR} passes through (5,6) and has the same y-intercept as line \overleftrightarrow{PS} , whose slope, m , is half the slope of line \overleftrightarrow{QR} . What is the equation, in standard form, of \overleftrightarrow{QR} ?

- A. $y - 2mx = 6 - 10m$
- B. $2y - mx = 12 - 5m$
- C. $y - 2mx = 10m - 6$
- D. $2y - mx = 5m - 12$

13. What is the solution to this system of equations?

$$\begin{cases} y + x = 5x + 3 \\ 12 - y = x + 2y \end{cases}$$

- A. $x = \frac{1}{4}, y = 4$
 - B. $x = \frac{6}{11}, y = \frac{63}{11}$
 - C. $x = \frac{3}{13}, y = \frac{51}{13}$
 - D. $x = \frac{21}{13}, y = \frac{45}{13}$
14. The amount, a , earned by Hari and Desmond by depositing money for a period of time, t , is the solution to these equations:

$$\begin{cases} 2a = 1600t + 20000 \\ 1.5a = 1280t + 14500 \end{cases}$$

What is the solution to this system of equations?

- A. $t = 0.2, a = 20,320$
- B. $t = 0.2, a = 10,160$
- C. $t = 6.25, a = 30,000$
- D. $t = 6.25, a = 15,000$

15. Luis multiplied 2 binomials to get the trinomial $x^2 - 9x + 20$. Which binomials did Luis multiply?
- A. $(x - 10)$ and $(x - 2)$
 - B. $(x - 4)$ and $(x - 5)$
 - C. $(x - 3)$ and $(x - 6)$
 - D. $(x + 4)$ and $(x + 5)$
16. A blueprint shows a rectangular basement with an area of $2x^2 - 9x - 5$. If the width of the basement is $x - 5$, what is the length of the basement?
- A. $(x + 1)$
 - B. $(2x - 1)$
 - C. $(2x + 1)$
 - D. $(2x^2 - 10x)$
17. What is the complete factorization of $5(a + 3)^2 - 13(a + 3) + 6$?
- A. $(5a - 3)(a - 2)$
 - B. $(5a + 12)(a + 3)$
 - C. $(5a + 12)(a + 5)$
 - D. $(5a + 12)(a + 1)$
18. Which expression is a perfect square trinomial?
- A. $121x^2 + 66x + 9$
 - B. $144x^2 + 60x + 25$
 - C. $169x^2 + 208x + 16$
 - D. $125x^2 + 200x + 16$
19. What is the complete factorization of $5y^2 - 45y^6$?
- A. $5y^2(1 - 3y^4)(1 - 3y^4)$
 - B. $5y^2(1 + 9y^4)(1 + 9y^4)$
 - C. $5y^2(1 + 3y^2)(1 - 3y^2)$
 - D. $5y^2(1 + 3y^3)(1 - 3y^3)$

20. Dina found that $\frac{x^2}{4} - 4x + 16$ represents the area of a certain square. Which expression represents a side of this square?

A. $\frac{x}{2} + 4$

B. $\frac{x}{2} - 4$

C. $\frac{x}{2} + 2$

D. $\frac{x}{2} - 2$

21. Karen correctly solved $x^2 + 3x = 18$ using the factoring method. What solutions did Karen find?

A. $x = -6, 3$

B. $x = 6, -3$

C. $x = -9, 2$

D. $x = 9, -2$

22. Solve the equation $12x^2 - 2x = 4$.

A. $x = \frac{1}{2}, -\frac{1}{2}$

B. $x = \frac{2}{3}, -\frac{1}{2}$

C. $x = \frac{2}{3}, -1$

D. $x = -\frac{2}{3}, \frac{1}{2}$

23. The area of a piece of sheet metal is $(3x - 1)^2$. What are the values of x when the area is 45 ft^2 ?

A. $x = 3\sqrt{5}, -3\sqrt{5}$

B. $x = \sqrt{5} - \frac{1}{3}, \sqrt{5} + \frac{1}{3}$

C. $x = 3\sqrt{5} + 1, -3\sqrt{5} - 1$

D. $x = -\sqrt{5} + \frac{1}{3}, \sqrt{5} + \frac{1}{3}$

24. What are the solutions to $x^2 - 3x - 24 = 0$?

A. $x = \frac{3 \pm \sqrt{105}}{2}$

B. $x = -3, 6$

C. $x = \frac{-3 \pm \sqrt{33}}{48}$

D. $x = 3, -6$

25. Which expression is the completely simplified form of $(y^{-6}y^4)^3$?

A. $\frac{1}{y^{72}}$

B. $\frac{1}{y^6}$

C. y^{27}

D. y^{30}

26. Evaluate this expression for $x = 2$ and $y = -1$.

$$\left(\frac{6x^2y^3}{2y^{-1}}\right)^{-1}$$

A. -12

B. -6

C. $\frac{1}{12}$

D. $\frac{3}{4}$

27. What is the completely simplified form of this expression?

$$\frac{(-3x^m x^n)^2 (3x^2)^n}{-(3x^n)^3}$$

A. $-(3^n x^{2m+2n})$

B. $-(3^{n-1} x^{2m+n})$

C. $(3^{n-1})(x^{2m+n})$

D. $(3^{n-1})(x^{m+n+1})$

28. Which expression is equivalent to $x^4y^3 \frac{(2m^{-1})^0}{(-2m)^2 x^{-3}}$?

A. $\frac{x^7y^3}{4m^2}$

B. $\frac{x^7y^3}{8m}$

C. $-\frac{xy^3}{4m^2}$

D. $-\frac{x^7y^3}{8m^3}$

29. The area of square $PQRS$ is $x^2 - y^2$. The area of square $JKLM$ is $x^2 - 3x + 2$. If $y = 1$, what is the simplified form of the ratio of the area of $PQRS$ to the area of $JKLM$?

A. $\frac{1}{3x+2}$

B. $\frac{x-2}{x+1}$

C. $\frac{x+1}{x-2}$

D. $\frac{x^2-1}{x^2-3x+2}$

30. What is the completely simplified form of $5\sqrt{7} - \sqrt{63} + 7\sqrt{(21)(3)}$?

A. $59\sqrt{7}$

B. $35\sqrt{7}$

C. $26\sqrt{7}$

D. $23\sqrt{7}$

31. In terms of x , what is the area of the shaded portion of this figure?

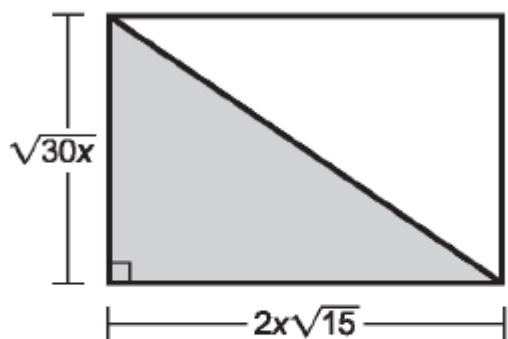

- A. $15x\sqrt{2x}$
B. $4x\sqrt{15x}$
C. $\frac{\sqrt{15}(\sqrt{2x} + 2x)}{2}$
D. $450x^2$
32. Which expression is equivalent to $\frac{2x^2y}{x\sqrt{y}}$?

- A. $2x\sqrt{y}$
B. $\frac{2xy}{\sqrt{y}}$
C. $\frac{2x\sqrt{y^2}}{y}$
D. $2xy - \sqrt{y}$

33. The numbers in this table follow a linear pattern:

u	v
-5	23
-3	15
2	-5
4	-13

Which is the linear relationship between u and v ?

- A. $v = -5u + 5$
B. $v - 8 = u + 2$
C. $v = -4u + 3$
D. $v = u + 28$
34. Which relationship exhibits a pattern of exponential growth?
- A. The amount saved is equal to the difference in amount of profit and amount spent.
B. The amount in an account results from 10% interest on \$1,000 compounded annually for 5 years.
C. The value of an old coin increases by \$80 each year.
D. Income is equal to the square of the number of toys sold each month.
35. A bag contains 10 red balls, 5 yellow balls, and 9 white balls. If Brian randomly draws a ball from the bag, puts it aside, and randomly draws another ball from the bag, what is the probability that Brian will draw 2 white balls?
- A. $\frac{1}{81}$
B. $\frac{3}{25}$
C. $\frac{1}{8}$
D. $\frac{3}{23}$

36. A total of 140 children participated in a spelling competition. This graph shows the relation between the number of children, n , who spelled words correctly and the number of letters, s , in the word spelled.

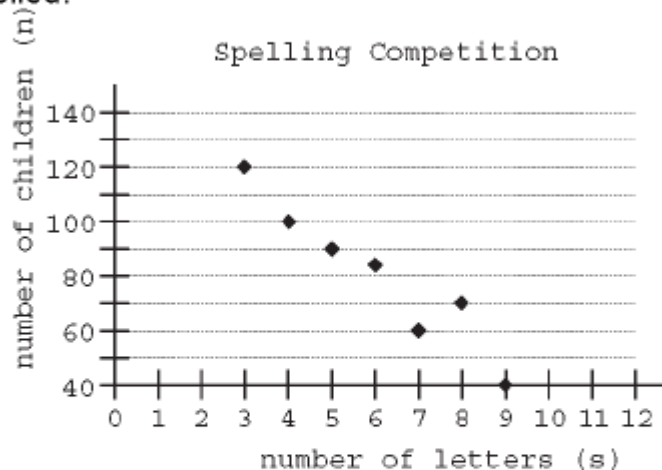

- Which equation most closely approximates the line of best fit?
- A. $n = -11s + 150$
 B. $n = -20s + 165$
 C. $n = 11s + 150$
 D. $n = 20s + 165$
37. A segment has a midpoint at $(3,4)$ and an endpoint at $(-2,3)$. What is the location of the other endpoint?
- A. $(0.5,3.5)$
 B. $(1,7)$
 C. $(8,5)$
 D. $(-7,2)$
38. On the (x,y) coordinate plane, $\triangle ABC$ has vertices at $A(-6,5)$, $B(-3,-2)$, and $C(1,2)$. What is the length of the segment that joins vertex A with the midpoint of \overline{BC} ?
- A. $5\sqrt{2}$
 B. $\sqrt{58}$
 C. $6\sqrt{2}$
 D. $\sqrt{74}$

39. An engineer must decide whether to build a road that climbs a hill or goes around it. To do so, he must determine the angle of elevation from horizontal ground to the top of the hill. To the nearest degree, determine the angle of elevation of this hill.

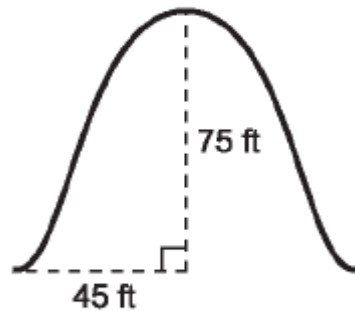

- A. 31°
- B. 37°
- C. 53°
- D. 59°

40. A child is standing at point C and flying a kite located at point A , 25 ft above the ground. As the child lets out more string, the kite rises to a point B , directly above point A . If the angle of elevation changes from 50° to 65° , how much higher, to the nearest foot, is the kite than it was initially?

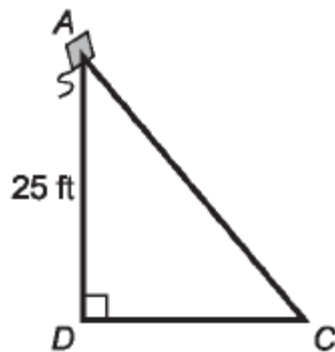

- A. 5
- B. 20
- C. 21
- D. 45

Honors Algebra 2 2010

Part I - Answer Sheet

Name _____

Choice e stands for “none of the above” and should be marked only if none of the solutions provided are correct.

1. A B C D E

2. A B C D E

3. A B C D E

4. A B C D E

5. A B C D E

6. A B C D E

7. A B C D E

8. A B C D E

9. A B C D E

10. A B C D E

11. A B C D E

12. A B C D E

13. A B C D E

14. A B C D E

15. A B C D E

16. A B C D E

17. A B C D E

18. A B C D E

19. A B C D E

20. A B C D E

21. A B C D E

22. A B C D E

23. A B C D E

24. A B C D E

25. A B C D E

26. A B C D E

27. A B C D E

28. A B C D E

29. A B C D E

30. A B C D E

31. A B C D E

32. A B C D E

33. A B C D E

34. A B C D E

35. A B C D E

36. A B C D E

37. A B C D E

38. A B C D E

39. A B C D E

40. A B C D E